



# TECHNICAL GUIDANCE

Low-price, compact

## RR930N/RR940N MINI UNIVERSAL CONVERTER

### OUTLINE

The RR900N series is a scaling conversion display unit for pulse signal input. It is ideal for pulse output type sensors such as wheel flowmeter sensors. In addition to an alarm function and digital signal processing functions such as linearization, it is equipped with pulse/analog output and a serial communication function to output converted values.

### FEATURES

- Pulse input handles both contact signals (open collector) and voltage signals (selectable).
- Scaling conversion through multipoint linearization
- High and low alarm function
- Pulse or analog output function (Analog output can be switched between current and voltage.)
- Two-wire RS-485 serial communication and multi-drop connection enable two or more units to communicate with each other.
- CE-mark, RoHS-compliant

### MODEL CODE

MODEL CODE		Description
RR	□□□□	
Output signal	930N	Re-pulse output, high / low alarm
	940N	Analog output, high / low alarm

### SPECIFICATIONS

#### Functional specifications

Input	Open collector pulse / voltage pulse (selectable) Max. voltage: 30 V, Current: up to 1 mA Detection level (low): 1 V / 2 V (selectable) Frequency: 0.1 Hz to 1.5 kHz, Pulse width: 0.3 ms or more
Measurement	Resolution: 0.01 Hz Accuracy: 0.05 % of reading $\pm 0.1$ Hz
Display	5-digit red LED Frequency: 0.0 to 1500.0 (fixed point) Conversion value: 0.000 to 12000 Indicator: 2 red LED lamps Alarm output (A) and frequency indication (H)
Operation key	MODE, SHIFT, UP and ENT
Alarm output	High / low alarm (selectable) Output rating: 30 V DC / 100 mA, ON resistance, 1 $\Omega$ or less Close / open at the output (selectable)
	[RR930N] Isolated open drain output: 1 [RR940N] Non-isolated open drain output: 1



Output	<b>[RR930N]</b> Re-pulsed output Pulse frequency signal proportional to the converted value Output range: 1 Hz to 1.5 kHz, Duty: 1:1 Output circuit: Open collector Output rating: 30 V DC / 10 mA Residual voltage: 0.6 V or less <b>[RR940N]</b> Analog output Current output: DC 4-20 mA (load: up to 400 $\Omega$ ) Voltage output: DC 0-5 V / 0-10 V (load: 500 k $\Omega$ or higher) (selectable) Accuracy: $\pm 0.2$ % of the reading at 23 $^{\circ}$ C $\pm 5$ $^{\circ}$ C Over-range: 120 % F.S. (0-10 V output is less than 120 %.)
Setting	Full scale frequency, converted value Low-cut off Updating cycle of indication Instrument address Pulse detection timeout Input (pull-up, detection level, high-cut filter) Transmission (speed and response delay time) Setup value for high / low alarm Alarm operation setup Linearization point, frequency, conversion value ----- <b>[RR930N]</b> Number of moving average samples Re-pulsed output scaling frequency, conversion value <b>[RR940N]</b> Damping time constant Analog output zero and span adjustment Analog output changeover
Communication type	RS-485 2-wire asynchronous serial communication Communication speed: 4800 to 38400 bps Command-response system Instrument address: 00 to 99 Response delay: variable up to 2 seconds
Power supply	12 V DC $\pm 10$ %, up to 25 mA

General specifications

Power voltage	10 to 27 V DC
Power consumption	Approx. 1.5 VA (max.) Approx. 2 VA (max.) for RR940N (4-20 mA output)
Operating environment	Storage: -20 °C to +60 °C, 90 % RH or less Operating range: +5 °C to +50 °C, 10 % RH to 90 % RH (without freezing or condensation)

Dimensions	W48 × H24 × D80 mm Panel cut: Based on DIN24 × 48
Mass	【RR930N】: Approx. 50 g 【RR940N】: Approx. 55 g
Material	Body: ABS resin Panel: Acryl

INPUT AND OUTPUT TERMINALS

RR930N

No.	Description	Function
1	POWER SOURCE (+)	Power supply (+)
2	POWER SOURCE (-)	Power supply (-)/re-pulsed output (-)
3	OUT-1	Alarm output (+)
4	OUT-2	Re-pulsed output (+)
5	RS485 (+)	RS-485 communication
6	RS485 (-)	
7	COM (OUT-1)	Alarm output (-)
8	POWER OUT	Power supply for the sensor (+)
9	GND	Power supply for the sensor (-) / input (-)
10	PULSE INPUT	Sensor input (+)

RR940N

No.	Description	Function
1	POWER SOURCE (+)	Power supply (+)
2	POWER SOURCE (-)/(OUT-1 GND)	Power supply (-) / alarm output (-)
3	OUT-1 (ALARM OUT O.C.)	Alarm output (+)
4	ANALOG OUT (DC V or DC A)	Analog output
5	ANALOG GND	
6	RS485 (+)	RS-485 communication
7	RS485 (-)	
8	SENSOR POWER OUT (+) (12V)	Power supply for the sensor (+)
9	SENSOR GND	Power supply for the sensor (-) / input (-)
10	SENSOR SIGNAL IN	Sensor input (+)

Suitable lead wire: AWG16 to 26

DIMENSIONS

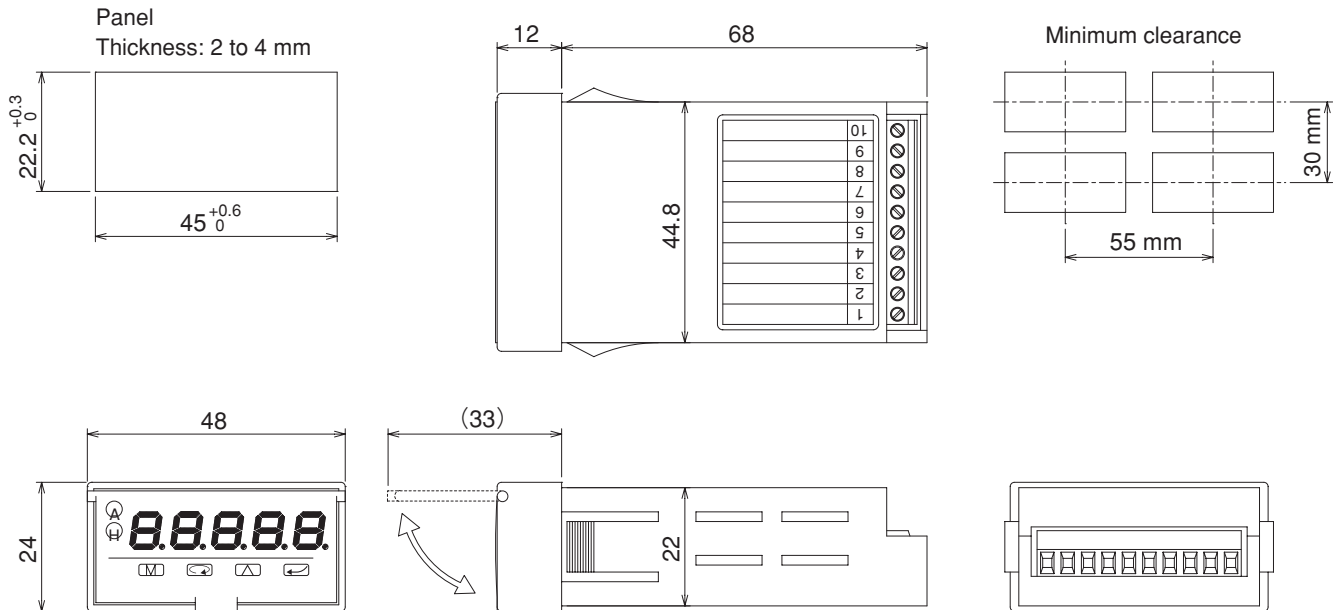

\* Specification is subject to change without notice.

**TOKYO KEISO CO., LTD.**

Head Office : Shiba Toho Building, 1-7-24 Shibakoen, Minato-ku, Tokyo 105-8558  
 Tel : +81-3-3431-1625 (KEY) ; Fax : +81-3-3433-4922  
 e-mail : overseas.sales@tokyokeiso.co.jp ; URL : http://www.tokyokeiso.co.jp

